

# Pedestrian stacker truck 1.2 ton

## BT staxio

*P-series*

SPE120XR

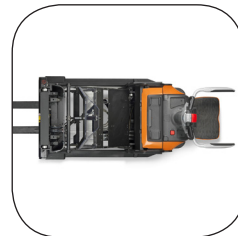

# Pedestrian stacker

Specifications					SPE120XR
Identification	1.1	Manufacturer			BT
	1.2	Model			SPE120XR
	1.3	Drive			Electric
	1.4	Operator type			Stand on/Pedestrian
	1.5	Load capacity/rated load	Q	kg	1200
	1.6	Load center	c	mm	600
	1.8	Load distance, centre of support arm wheel to face of forks	x	mm	DXT/DXH=677, TX=660
	1.9	Wheelbase	y	mm	1515
	Weight	2.1	Service weight incl. battery		kg
2.3		Axle load, mast retracted without load, drive/fork wheel		kg	1255/620
2.4		Axle load, mast extended with load, drive/fork wheel		kg	280/2795
2.5		Axle load, mast retracted with load, drive/fork wheel		kg	1235/1840
Wheels		3.1	Drive/caster/fork wheel		
	3.2	Wheel size, front		mm	140
	3.3	Wheel size, rear		mm	250
	3.7	Track width, rear	b <sub>11</sub>	mm	810/995
Dimensions	4.2	Height, mast lowered	h <sub>1</sub>	mm	2224
	4.3	Free lift	h <sub>2</sub>	mm	1734
	4.4	Lift	h <sub>3</sub>	mm	4750
		Lift height	h <sub>23</sub>	mm	4800
	4.5	Height, mast extended	h <sub>4</sub>	mm	5320
	4.8	Stand height	h <sub>7</sub>	mm	190
	4.9	Height of tiller in drive position, min./max. highest setting	h <sub>14</sub>	mm	1201/1413
		lowest setting	h <sub>14</sub>	mm	1101/1313
	4.10	Height of support arms	h <sub>8</sub>	mm	160
	4.15	Height, fork lowered	h <sub>13</sub>	mm	50
	4.19	Overall length, platform up/down	l	mm	2005/2455
	4.20	Length to face of forks, platform up/down	l <sub>2</sub>	mm	1095/1520
	4.21	Overall width	b <sub>1</sub> /b <sub>2</sub>	mm	900/1085
	4.22	Fork dimensions	s/e/l	mm	40/100/1150
	4.25	Width over forks	b <sub>5</sub>	mm	Wide=250-750, Narrow=250-570
	4.26	Distance between support arms	b <sub>4</sub>	mm	665/850
	4.28	Reach distance	l <sub>4</sub>	mm	790
	4.31	Ground clearance, center of wheelbase	m <sub>1</sub>	mm	30
	4.32	Ground clearance, center of wheelbase	m <sub>2</sub>	mm	40
4.33	Aisle width for pallets 1000 × 1200 crossways, platform up/down	A <sub>st</sub>	mm	2641/3091	
4.34	Aisle width for pallets 800 × 1200 lengthways, platform up/down	A <sub>st</sub>	mm	2618/3068	
4.35	Turning radius, platform up/down	W <sub>a</sub>	mm	1760/2210	
4.37	Length across support arms, platform up	l <sub>7</sub>	mm	1830	
Performance data	5.1	Travel speed, with/without load 6 km/h version		km/h	6,0/6,0
		8 km/h version		km/h	7,5/8,0
	5.2	Lift speed, with/without load		m/s	0,20/0,36
	5.3	Lowering speed, with/without load		m/s	0,45/0,45
	5.4	Reach speed, with/without load		m/s	0,15/0,15
	5.8	Max. gradeability, with/without load <sup>1)</sup>		%	8/10
	5.9	Acceleration time (over 10 m)		s	5,7
5.10	Service brake			Electromagnetic	
Electric motor	6.1	Drive motor rating (S2 60min) 6 km/h version		kW	1,8
		8 km/h version		kW	1,8
	6.2	Lift motor rating (S3 15%)		kW	3,0
	6.4	Battery voltage, nominal capacity K5		V/Ah	24/300
	6.5	Battery weight		kg	195-270
	6.6	Energy consumption acc to VDI cycle		kWh/h	1,22
Others	8.1	Type of drive control			Variable AC
	8.4	Sound level at the driver's ear according to EN 12 053		dB (A)	59

1) Measured according to company standard.

Data is based on standard truck and small battery.

All data are based on table configuration. Other configurations may give other values.

Truck performance and dimensions are nominal and subject to tolerances.

Toyota Material Handling Manufacturing Sweden and specifications are subject to change without notice.

# Mast dimensions

SPE120XR			Duplex Tele							Duplex HiLo							Triplex HiLo				
$h_{23}$	Lift height ( $h_{13}+h_3$ )	mm	2350	2500	2800	3300	3700	4150	2350	2500	2800	3300	3700	4150	3300	3700	3950	4150	4500	4800	
$h_3$	Lift	mm	2300	2450	2750	3250	3650	4100	2300	2450	2750	3250	3650	4100	3250	3650	3900	4100	4450	4750	
$h_1$	Height, mast lowered	mm	1722	1797	1947	2197	2397	2622	1722	1797	1947	2197	2397	2622	1724	1857	1940	2007	2124	2224	
$h_2$	Free lift	mm	132	132	132	132	132	132	1242	1316	1466	1716	1916	2142	1234	1366	1450	1516	1634	1734	
$h_4$	Height, mast extended	mm	2798	2948	3248	3748	4148	4598	2880	3030	3330	3830	4230	4680	3820	4219	4468	4669	5020	5320	

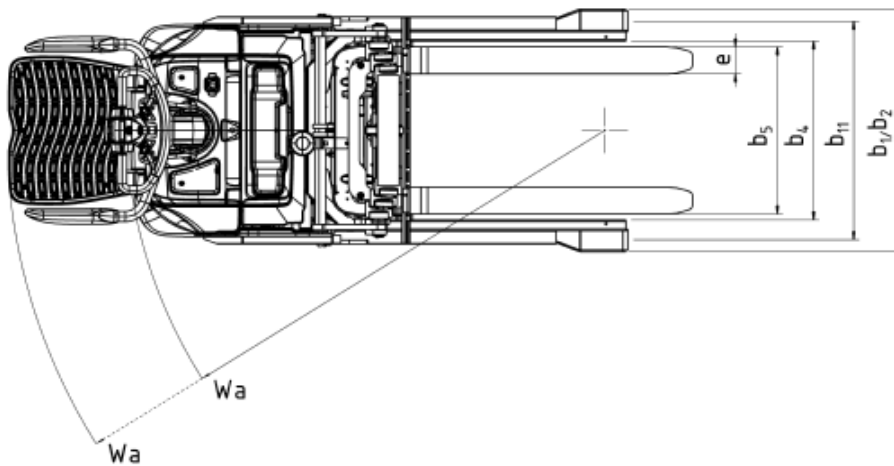
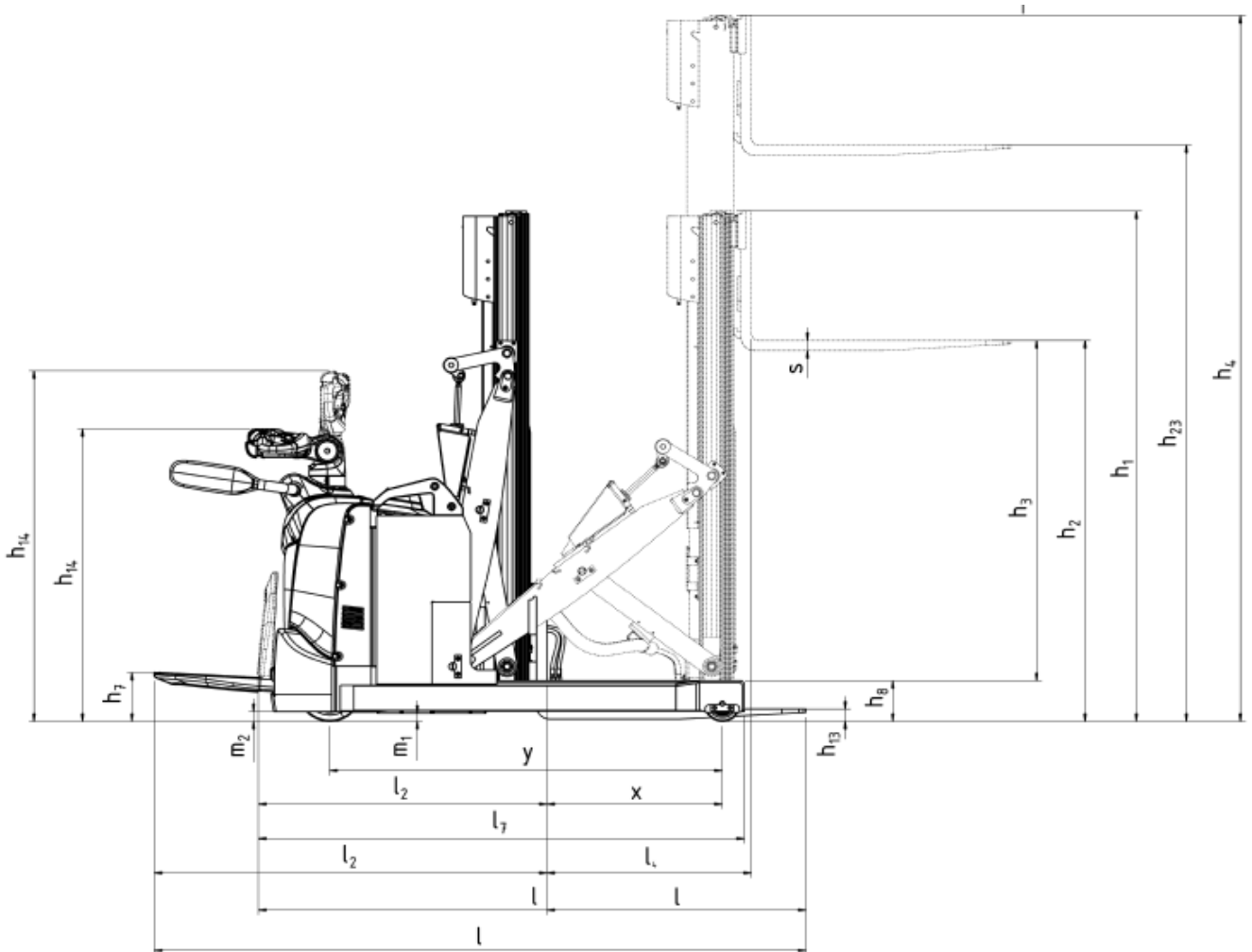

---

## Truck features:

- 180°+ Power/Electronic steering
- Optimised Truck Performance
- Reach mast with Pantograph fork mechanism
- Mast tilt
- Adjustable fork width
- Sensi-lift
- Height adjustable tiller arm
- One-touch foldable gates
- Click-2-Creep
- Electronic fingertip controls for all functions
- Access control
- Driver-adapted programmable performance
- Easy access for maintenance
- Sideshift and spreader attachment (option)
- I\_Site (option)
- Li-Ion battery (option)
- Coldstore version (option)

